

660 & 1100 LITRE FOUR WHEELED BINS

European heritage – Australian made



660 LITRE AU BIN

For Commercial, Industrial and High Density Residential collections



1100 LITRE AU BIN

For Commercial, Industrial and High Density Residential collections

The SULO Difference

- Manufactured locally from high quality materials to ensure compliance to AS-4123
- Withstands exposure to high mechanical stress levels*
- Engineered to withstand Australian climatic conditions
- Resistant to decay, frost, heat and chemicals
- Post consumer recycling content (PCR)
- Recyclable at end of life

Maximum Safety

- Built in grip handles for safe movement and collection
- Robust body, lid, hinge and wheel design and manufacture
- Heavy duty steel hubs, 2 with braking locks and directional locks optional
- Easy opening lid with multiple grip handles

Quality Assurance

- Locally Made using Australian sourced recycled materials
- Locally supported for Service and parts
- Locally tested and compliant to AS-4123 standard: now and ongoing
- Made with high quality HDPE and rHDPE

Benefits

- Locally made, locally supplied, locally supported
- SULO network of Australia wide warehouses for local shipment
- Customised, as required
- Use of locally sourced PCR and recyclable at end of life
- Large volume, small footprint



Customisation



STANDARD COLOURS READILY AVAILABLE: GREEN/BLACK BODIES AND RED, GREEN, YELLOW AND BLUE LIDS



CUSTOM COLOURS AVAILABLE UPON REQUEST WITH MOQ APPLICABLE



HOT STAMPING IMPRINTS FOR SERIAL NUMBERS AND BRANDING



ADHESIVE LABELS



RFID TAGS



PERCENTAGE OF PCR

TECHNICAL SPECIFICATIONS

660 LITRE AU BIN

DIMENSIONS

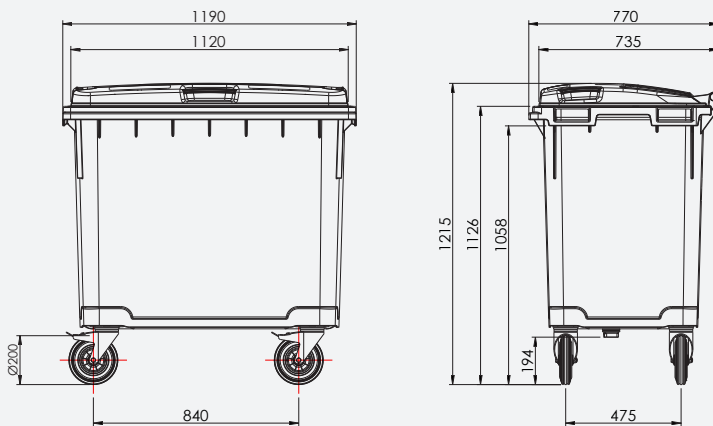

VOLUME

Nominal volume (L)	660
Net weight (kg)	42
Max load (kg)	264
Permitted total weight (kg)	306

1100 LITRE AU BIN

DIMENSIONS

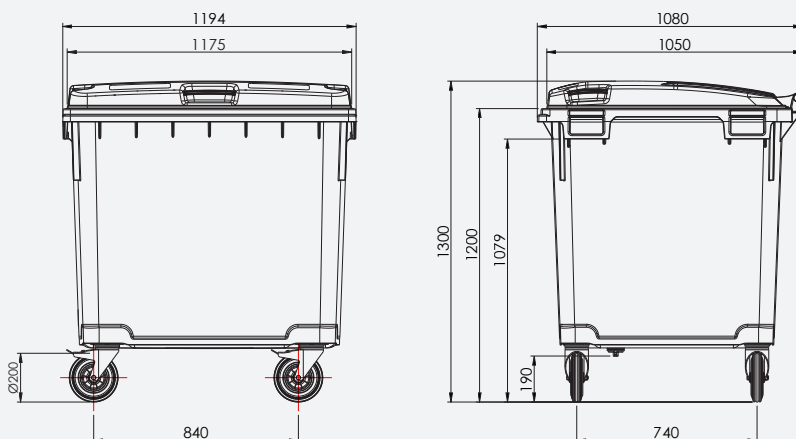

VOLUME

Nominal volume (L)	1100
Net weight (kg)	54
Max load (kg)	440
Permitted total weight (kg)	494

Contact Us